

E960

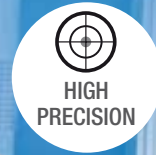

TURBINE ALIGNMENT

Straightness measurement of diaphragms and bearing journals



STRAIGHTNESS THE EASY WAY

RELIABILITY AND PRECISION

Easy-Laser® E960 makes the measurement and adjustment work of diaphragms and bearings easier thanks to the wireless detector unit and measurement programs that guides you through the measurement process. All of the parts included in the systems are designed and built for even the most demanding workplace and for easy setup on any machinery. The versatile design solves the straightness measurement problems quickly and with precision for any kind of application. Objects up to 40 m [132 feet] can be measured. The detector reads measurement values with a resolution of 0.001 mm [0.05 mils].

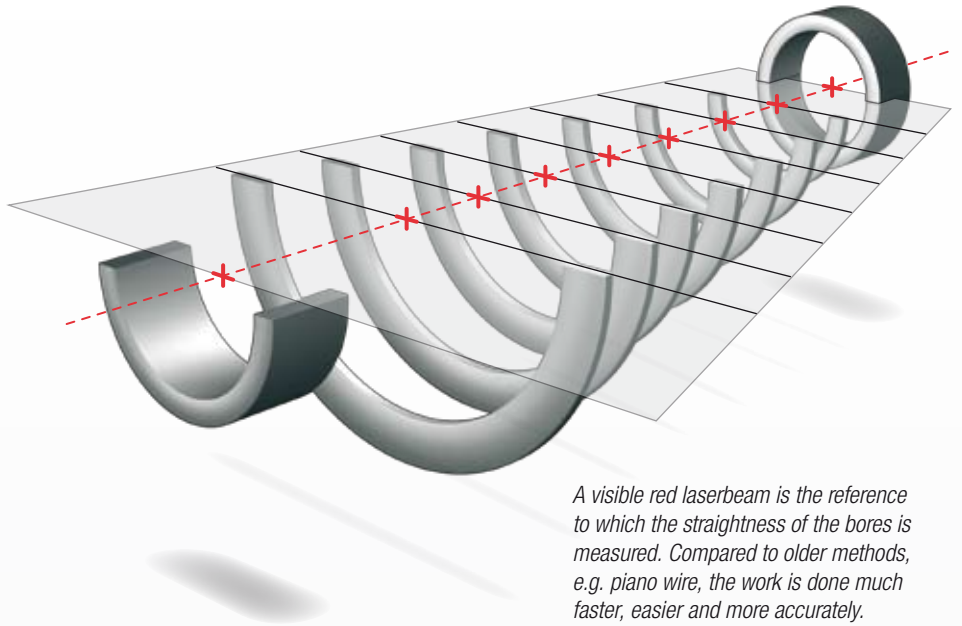

A visible red laserbeam is the reference to which the straightness of the bores is measured. Compared to older methods, e.g. piano wire, the work is done much faster, easier and more accurately.

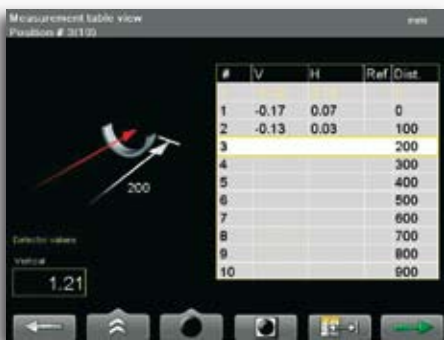

1. You set the number of measurement points and the distance between them in advance, or as the measurement continues. The distances can be equal or individual.



2. The graphics shows the detector direction. Markings on the circle shows active measurement point. Measurement value, and angular position for the detector (A).



3. "Live" adjustment of the measurement object. Vertical and horizontal value for the object (B). Markings on the circle shows zone for adjustment with live values (C).

VERSATILE PROGRAMS

The straightness programs of system E960 are very versatile, and let you work in the way that suits every job best. You can add, remove and remeasure measurement points at any time during the measurement. Up to 999 points can be handled by the program. You can include both full bores and half bores in any possible combination in one measurement, the program will calculate the correct centre line in all cases. Optionally a reference detector can be used to monitor the laser transmitter position at long distances.



The measurement program includes many different methods for straightness measurement:
 A: 1-point measurement, B: 4-point measurement, C: Multipoint measurement (also ovality measurement),
 D: 3-point measurement, E: 3-point measurement with arbitrary angles,
 F: Multipoint measurement

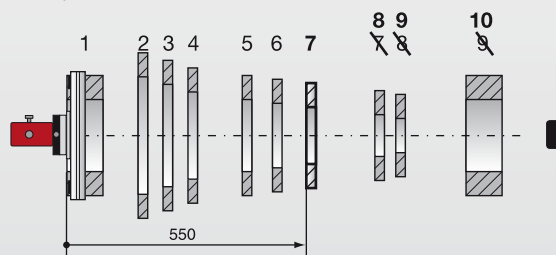

It's easy to add measurement points anywhere on the object in an existing measurement. The following points will be renumbered automatically. If you remove a point the following will be renumbered according to the same principle. If you remeasure a point, the old values will be saved in a history data base for possible later comparison. All this you can do at any time during the measurement!

THE MEASUREMENT RESULT

Thanks to the large colour display with clear graphs and measurement data you can evaluate the result directly on site. Any point can be set as reference and you can set an offset to which the centre line will be recalculated. You can also calculate waviness (short and long) and best-fit for the points. If you want, the result can also be checked against a tolerance value. The measurement system takes care of all these complicated calculations for you.

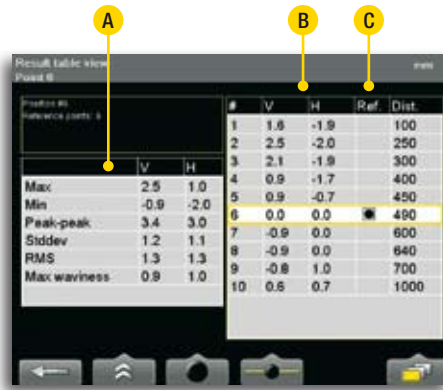

Result display with statistics to the left (A) and table with values to the right (B). The reference points are clearly marked (C).

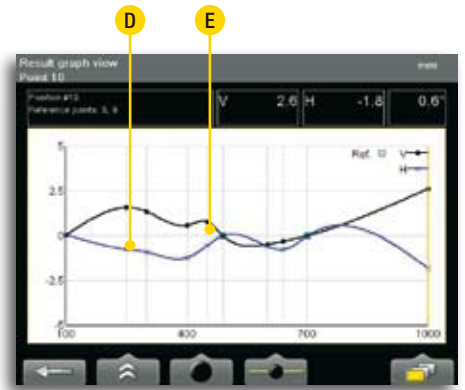

The result can also be shown as a graph (sharp or interpolated). You can zoom in or show the whole graph. Horizontal values (D) and vertical values (E).

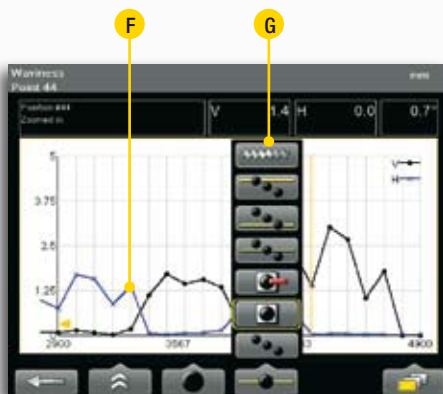

You can quickly change what the graph shows (G) for different calculation settings, for example Best fit and Waviness as shown here (F).



The result displayed as "Best fit around 0" (H), and with sharp graph.

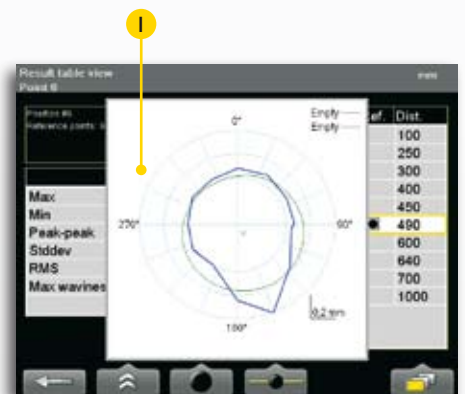

By using the Multipoint method you can get a clear view of possible bore ovality (I).

DOCUMENTATION

SAVE TO USB MEMORY

You can easily save desired measurements on your USB memory. This enables you to take it to your computer to print reports whilst leaving the measurement system in place to continue measuring.

SAVING IN THE BUILT-IN MEMORY

You can, of course, save all measurements in the display unit's internal memory. You can then open an old measurement and remeasure those points you adjusted.



CONNECT TO YOUR COMPUTER

The display unit is connected to the computer via the USB port. It then appears on the desktop as a "Mass Storage Device" which you can easily transfer files to and from.

CONNECT TO PRINTER

Connect a thermal printer (accessory) and print locally. Good for example when you want to see the values before and after adjustment, or want to leave a documentation of the measurement on site.

CREATE A PDF REPORT DIRECTLY

When measurement is complete it is possible to generate a PDF report containing graphs and measurement data directly in the measurement system's display unit. All the information about the measurement object is documented, and you can add your company's logo and address details if you so wish.



THE PARTS OF THE SYSTEM

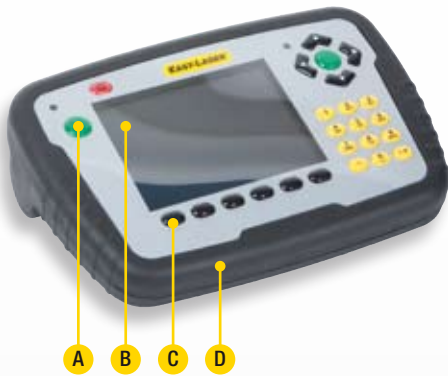

- A. Two Enter buttons, for left and right-handed users
- B. Large, easy to read colour display
- C. Proper buttons for clear feedback
- D. Thin profile gives a perfect grip for your hands



- E. Battery compartment
- F. Robust, rubber coated design
- G. Dust and splash guards for connectors that are not used when measuring
- H. Mounting for shoulder strap

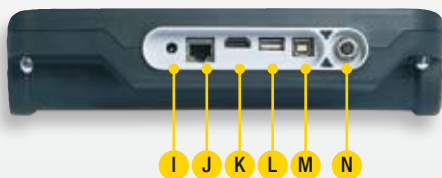

- I. Connection for charger
- J. Network connection
- K. Expansion port
- L. USB A
- M. USB B
- N. Easy-Laser® measurement equipment



- A. Well protected connectors
- B. PSD (1 axis)

Bluetooth® unit



DISPLAY UNIT

The display unit for the E series enables you to work more efficiently and for longer than ever before thanks to several innovative solutions. It is also ergonomically designed with easy-to-grip rubber cladding and robust construction.

NEVER LOSE POWER!

The display unit is equipped with our Endurio™ Power management system. This ensures that you never have to stop in the middle of a measurement because the battery has run out.



PERSONAL SETTINGS

You can create a user profile where you can save your personal settings. You can also have different settings for different types of measurements.

LANGUAGE SELECTION

You can choose the language you want to appear on the screen: English, German, French, Spanish, Portuguese, Finnish, Russian, Dutch, Korean, Chinese and Swedish are available. More languages to follow.

ERGONOMIC

The display unit has a thin, easy-to-grip and rubber coated profile that ensures a secure grip. It has large well-spaced buttons that give clear feedback when pushed. In addition, the two Enter buttons make the system suitable for both right and left-handed users. The display screen has clear graphics that guide you through the measurement process.

VALUES PROGRAM

All our measurement systems come with the universal Values program. It works like digital dial indicators. With this, you can, in principle, measure any type of geometry. Many Easy-Laser® users therefore end up using the measurement system in many more places in their operation, than they first intended!

UPGRADING

If you wish to expand functionality in the future, the software in the display unit can be upgraded via the internet or by connecting a USB memory containing the new software.

DETECTOR

Detector E4 connects to the display unit via cable or wirelessly. The unit for wireless communication is easily inserted into one of the connectors on the detector. The substantial and rigid design guarantees stable measurement values and reliable alignment with the greatest precision in even the toughest of environments. The detector is also water and dust proof to classes IP66 and IP67.

With built-in electronic inclinometer the system knows exactly how the detector is positioned. It has large 20 mm [0.78" sq] detector surface (PSD for the greatest accuracy).

LASER TRANSMITTER BRACKET

The laser transmitters' rigid design assures highest measurement accuracy. The laser transmitter bracket spans over the bore with a sturdy aluminium beam with two or three magnet bases. Fine adjustment of the laser beam in horizontal and vertical direction is made very easy with the offset hub.

Optionally: The offset hub can be mounted with arms instead. The set includes three sets of adjustable arms with magnets to fit different diameters.

A & B: LASER TRANSMITTER WITH BRACKET

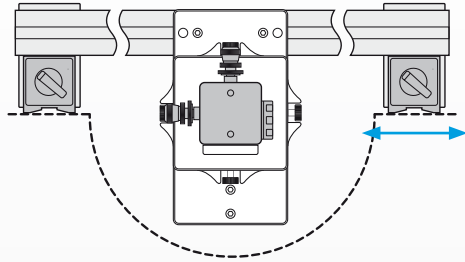
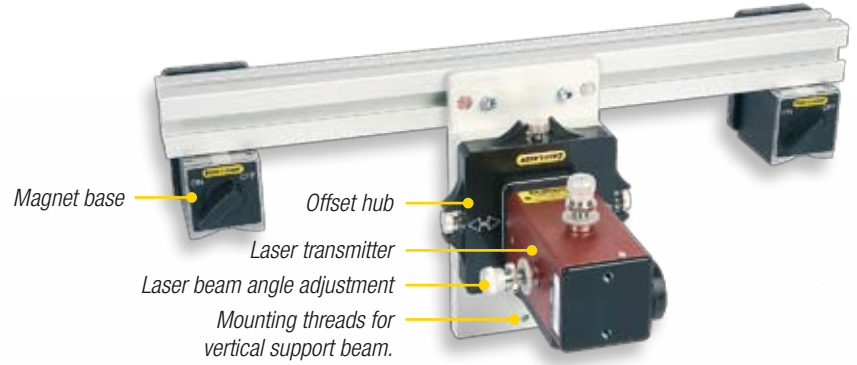

The setup of the bracket is very quick thanks to easily adjusted magnet bases and laser transmitter.

OPTIONAL MOUNTING WITH ARMS (ACCESSORIES)

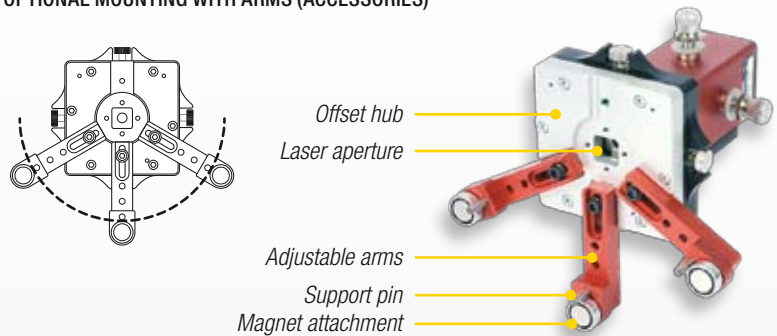

DETECTOR BRACKETS

The detector bracket comes in two versions. A: Measuring probe with a stroke of 10 mm. The slidable tube makes it possible to measure several positions in a row without moving the bracket. Suitable for gas turbines and smaller steam turbines.

B: Measuring probe with a stroke of 60 mm. Suitable for larger turbines.

A: DETECTOR BRACKET SHORT STROKE

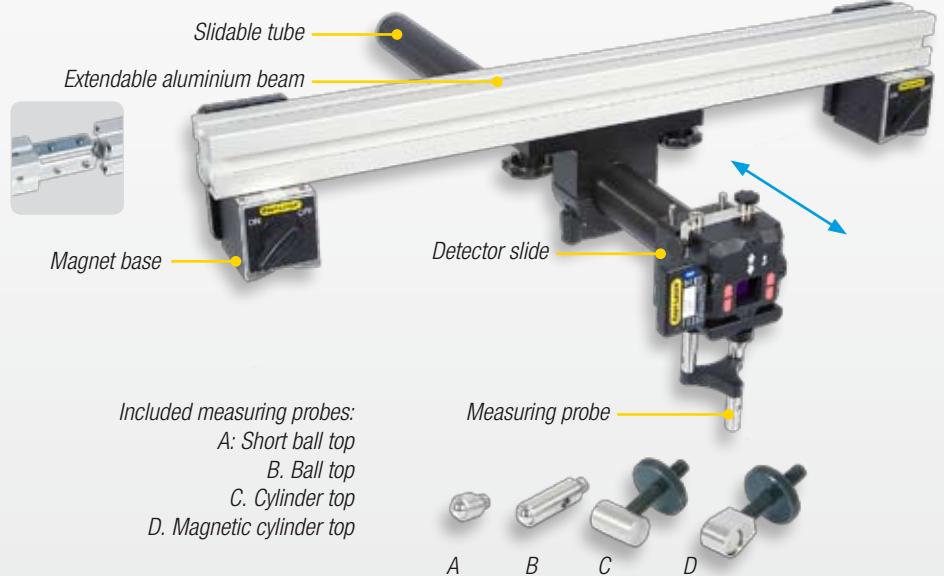

Detector slide mounted without tube (left).
Detector mounted to receive laser beam from opposite side (right). Also possible with tube.

B: DETECTOR BRACKET LONG STROKE

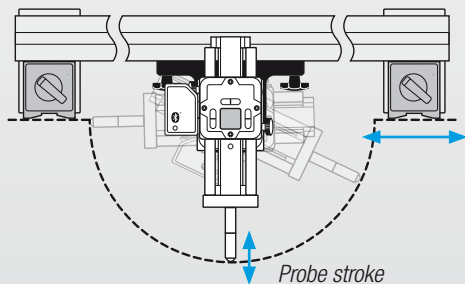

The measuring principle is the same for bracket A and B. The probe rod is very easily adapted to each diameter with extensions of different length (right). Bracket A has a stroke of 10 mm, B 60 mm.

EXPANDABILITY / ACCESSORIES



LASER TRANSMITTER D22

Laser transmitter D22 can be used to measure flatness, straightness, squareness and parallelism. For example flatness of parting surfaces. The laser beam can sweep 360° with a measurement distance of up to 40 metres [130'] in radius. The laser beam can be angled 90° to the sweep, within 0.01mm/m [0.5 mils/INCH].

Part No. 12-0022

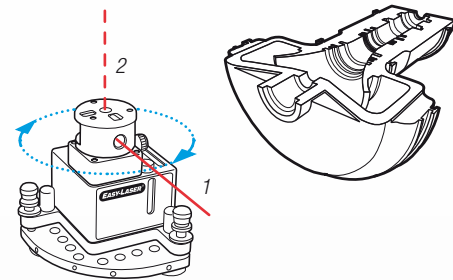

Option 1: the laser beam is used for a 360° sweep.
Option 2: the laser beam is angled at 90° to the sweep.



LASER TRANSMITTER D25

This transmitter can be used when an axial surface of the turbine is reference. The laser beam can be angled 90° to the turbine centre line. The detector is placed on three points and the beam is adjusted to the axial reference plane determined by these.

Part No. 12-0706

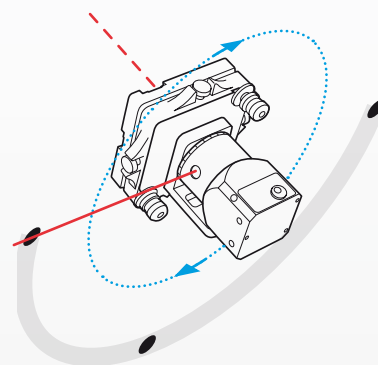

ARM KIT WITH MAGNETS



For use with the coordinate table instead of the included beam bracket. Part No. 12-0707

CHARGER 12–36 V



To charge the display unit via 12–36 V socket, for example in a car. Part No. 12-0585

EXTENSION CABLES



Length 5 m [16.4'], Part No. 12-0108
Length 10 m [32.8'], Part No. 12-0180

PROTECTIVE COVER



Protective case for display unit. With shoulder strap. Part No. 01-1379

MAGNETIC BRACKET



For laser transmitter D75. To use on shaft ends, flywheels, etc. Part No. 12-0187

REFERENCE DETECTOR



Detector for monitoring the position of the laser transmitter. Part No. 12-0509

EXTENSION ARMS

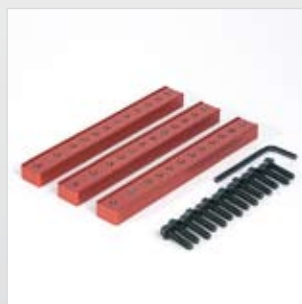

Extension arms 500–1000 mm [19.68"–39.36"']. Set for D75 with offset hub. Part No. 12-0282

PRINTER



Compact thermal printer. Connected in the USB port. Part No. 03-1004

TECHNICAL DATA

System	
Relative humidity	10–95%
E960-A: Weight	30.3 kg [66.8 lbs] (complete system)
E960-A: Carrying case	WxHxD: 1220x460x170 mm [48.0x18.1x6.7"]
E960-B: Weight	31.5 kg [69.4 lbs] (complete system)
E960-B: Carrying case	WxHxD: 1220x460x170 mm [48.0x18.1x6.7"]
Carrying cases	Drop tested. Water and dust tight. With wheels.

Laser transmitter D75 with offset hub	
Type of laser	Diode laser
Laser wavelength	635–670 nm, visible red light
Laser Safety Class	Class 2
Output	< 1 mW
Beam diameter	6 mm [1/4"] at aperture
Working distance	40-metre [130']
Type of battery	1 x R14 (C)
Operating time/battery	approx. 15 hours
Operating temperature	0–50 °C
Laser adjustment	D75: 2 ways ±2° (± 35 mm/m), Hub: ±5 mm in two axes
Housing material	Aluminium
Dimensions D75	WxHxD: 60x60x120 mm [2.36x2.36x4.72"]
Dimensions D75 with Hub	WxHxD: 135x135x167 mm [5.31x5.31x6.57"]
Weight	2385 g [84.13 lbs]

Laser transmitter bracket (included in system E960-A and E960-B)	
Measurement diameters	∅ 250–1200 mm [9.84"–47.24"]
	Up to 4000 mm with extension beams (accessories)
Magnet bases	3 pcs, holding power 800 N/each

Detector E4	
Type of detector	1 axis PSD 20x20 mm [0.78" sq]
Resolution	0.001 mm [0.05 mils]
Measurement error	± 1% +1 digit
Inclinometers	0.1° resolution
Thermal sensors	± 1° C accuracy
Environmental protection	IP Class 66 and 67
Operating temperature	-10–50 °C
Internal battery	Li Po
Housing material	Anodized aluminium
Dimensions	WxHxD: 60x60x42 mm [2.36x2.36x1.65"]
Weight	186 g [6.6 oz]

Detector bracket Short stroke (included in system E960-A)	
Measurement diameters	∅ 150–1700 mm [5.9"–66.9"]
Stroke	10 mm [0.4"]
Magnet bases	2 pcs, holding power 800 N/each
Material	Anodized aluminium
Weight	4900 g [10.8 lbs] (with magnets)

Detector bracket Long stroke (included in system E960-B)	
Measurement diameters	∅ 200–1700 mm [7.8"–66.9"]
	Up to 4500 mm with extension beams and rods (accessories)
Stroke	60 mm [2.36"]
Magnet bases	2 pcs, holding power 800 N/each
Material	Anodized aluminium
Weight	4900 g [10.8 lbs] (with magnets)

Centering targets	
Diameters	∅ 100–1500 [3.93"–59"]

Cables	
Type	With Push/Pull connectors
System cable	Length 2 m [78.7"]
Extension system cable	Length 5 m [196.8"]
USB cable	Length 1.8 m [70.8"]

Display unit	
Type of display/size	VGA 5.7" colour
Displayed resolution	0.001 mm / 0.05 thou
Power management	Endurio™ system for unbroken power supply
Internal battery (stationary)	Li Ion
Battery compartment	For 4 pcs R 14 (C)
Operating time	Appr. 30 hours (Normal operating cycle)
Operating temperature	-10–50 °C
Connections	USB A, USB B, External, Easy-Laser® units, Network
Wireless communication	Class I Bluetooth® Wireless Technology
Storage memory	>100,000 measurements
Help functions	Calculator, Unit converter
Environmental protection	IP Class 65
Housing material	PC/ABS + TPE
Dimensions	WxHxD: 250x175x63 [9.8x6.9x2.5"]
Weight (without batteries)	1030 g [2.3 lbs]

Wireless connection unit	
Wireless communication	Class I Bluetooth® Wireless Technology
Operating temperature	-10–50 °C
Environmental protection	IP Class 66 and 67
Housing material	ABS
Dimensions	53x32x24 mm [2.1x1.2x0.9"]
Weight	25 g [0.9 oz]

CUSTOM DESIGN

In addition to our already versatile standard system we can also specially adapt measurement systems to suit your needs. Using our own CNC machines we can quickly manufacture brackets just for you. This means for example that brackets for other diameters than mentioned on this page can be manufactured on request.

WARRANTY AND SERVICE CONCEPT

The Easy-Laser® systems have evolved over more than 25 years, through field experience in solving measurement and alignment problems. The systems come with a 3 year limited warranty*. The manufacturing and quality systems are ISO9001 approved. If an incident should occur, our service department normally handles repairs and calibrations within five working days. This combination makes Easy-Laser® a reliable partner for your business.

* Extend the warranty from 2 to 3 years by registering your system on the Internet.



SYSTEMS

EASY-LASER® E960-A

This system is suitable for gas turbines and smaller steam turbines. Measures diameters 150–1700 mm [5.9"–67"]. The detector bracket comes with a slidable tube, making it possible to measure several positions in a row without moving the bracket.

A complete system contains

1	Laser transmitter D75
1	Detector E4
1	Display unit
1	Bluetooth® unit
1	Cable 2 m
1	Cable 5 m (extension)
1	Offset hub for D75
1	Transmitter bracket, with 3 magnet bases
1	Detector bracket Short stroke , with 2 magnet bases
1	Detector probe top set
2	Target for centering of brackets
1	Manual
1	Measuring tape 5 m
1	USB memory stick
1	USB cable
1	Battery charger (100–240 V AC)
1	Toolbox
1	Shoulder strap for display unit
1	Cleaning cloth for optics
1	CD with documentation
1	Carrying case (with wheels)

System Easy-Laser® E960-A, Part No. 12-0710



EASY-LASER® E960-B

System suitable for larger turbines. Measures diameters 200–1700 mm [7.8"–67"] as standard, and up to 4500 mm [177"] with accessory brackets. The detector bracket has a probe stroke of 60 mm [2.4"], which is convenient when nearby bore diameters vary a lot.

A complete system contains

1	Laser transmitter D75
1	Detector E4
1	Display unit
1	Bluetooth® unit
1	Cable 2 m
1	Cable 5 m (extension)
1	Offset hub for D75
1	Transmitter bracket, with 3 magnet bases
1	Detector bracket Long stroke , with 2 magnet bases
2	Target for centering of brackets
1	Manual
1	Measuring tape 5 m
1	USB memory stick
1	USB cable
1	Battery charger (100–240 V AC)
1	Toolbox
1	Shoulder strap for display unit
1	Cleaning cloth for optics
1	CD with documentation
1	Carrying case (with wheels)

System Easy-Laser® E960-B, Part No. 12-0711



Easy-Laser® is manufactured by Damalini AB, Alfagatan 6, SE-431 49 Mölndal, Sweden

Tel +46 (0)31 708 63 00, Fax +46 (0)31 708 63 50

e-mail: info@damalini.se, www.damalini.com

© 2011 Damalini AB. We reserve the right to make changes without prior notification.

Easy-Laser® is a registered trademark of Damalini AB. Other trademarks belong to the relevant copyright holder. This product corresponds to: EN60825-1, 21 CFR 1040.10 and 1040.11
This device contains FCC ID: PVH0925, IC: 5325A-0925.



CE 05-0599 Rev1